

Comparison of different Fault-Ride-Through solutions for gas engine power plants based on simulations

Eckehard Tröster
Energynautics GmbH

Gerd Krieger
VDMA Power Systems

PLUG INTO THE GRID



8-10 June 2010 | RAI, Amsterdam, The Netherlands

POWERGRID
EUROPE 
www.powergrideurope.com

- Background
- Task
- Base Model
- FRT Solutions
 - Inertia
 - Parallel Braking Resistor (PBR)
 - Series Braking Resistor (SBR)
 - Full Power Converter (FPC)
 - Eddy-Current Brake (ECB)
- Conclusions

- In 2008, the new German grid codes for the medium voltage level¹ were released
- Generating plants have to stay connected to the grid during a short circuit in the power system
- Problems:
 - the generator accelerates and might fall out of step,
 - high short-circuit currents and torques will appear,
 - uncontrolled resynchronization when fault is cleared
- First ideas for simulation studies were discussed in July 2009
- An international working group of 8 companies from 5 countries was formed

¹ Technische Richtlinie Erzeugungsanlagen am Mittelspannungsnetz –
Richtlinie für Anschluss und Parallelbetrieb von Erzeugungsanlagen am Mittelspannungsnetz,
Ausgabe Juni 2008, Bundesverband der Energie- und Wasserwirtschaft e.V. (BDEW), Berlin 2008

- Simulation of gas engine power plants
- Power rating from 200kW to 10MW
- Investigation of the behavior during a fault in the electrical power system
- 5 different FRT solutions
- Real gen-set combinations have been chosen to be able to compare against measurement data

The model is not yet validated!
→ Simulation results can only give tendencies

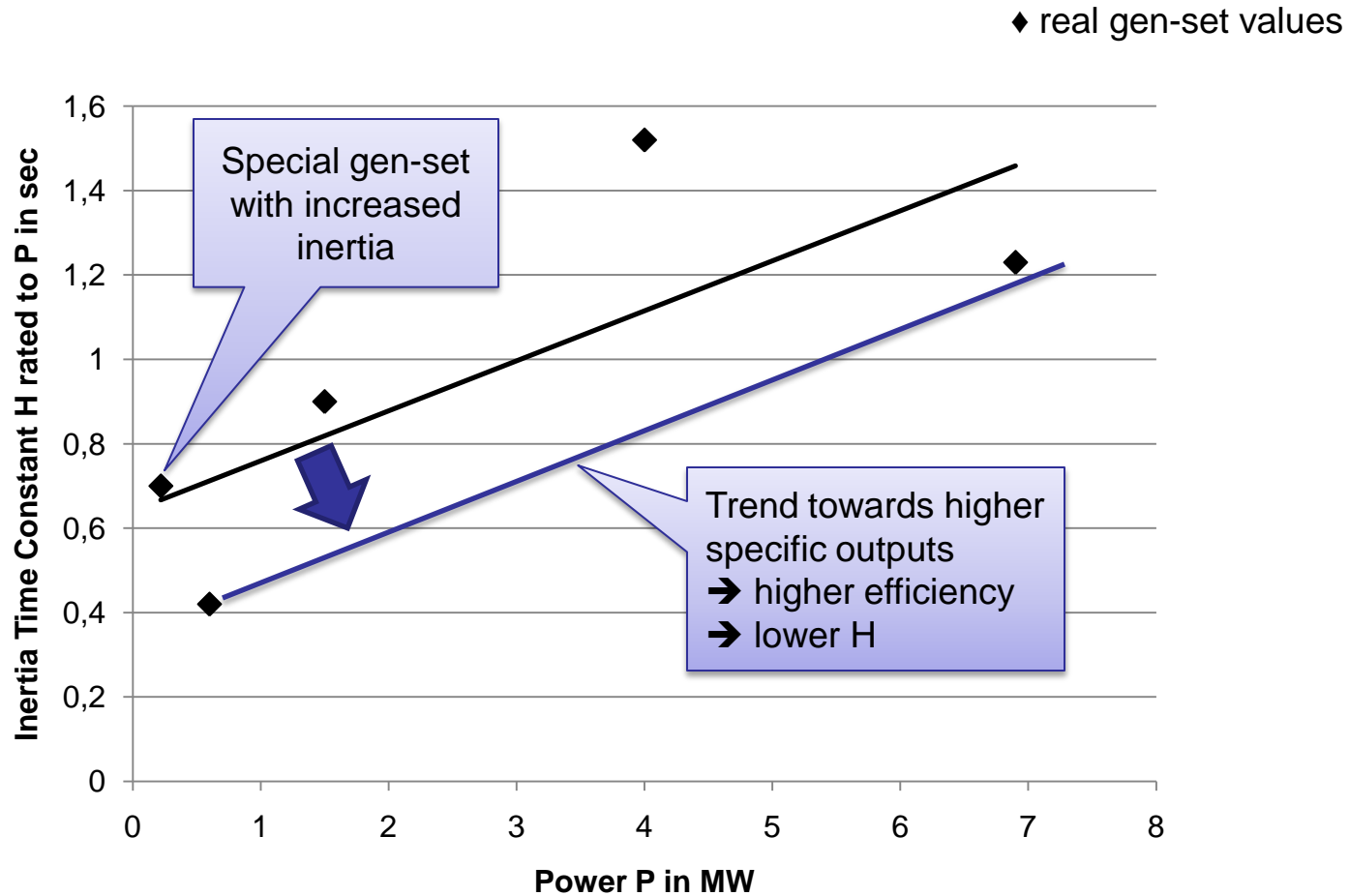

A series of simulations have been performed in order to determine the stability of the CHPs during a grid fault. These comply with the technical guidelines part 3 of the FGW² :

Test No.	Voltage (V/V ₀)	Duration (ms)
1	0	150
2	0.20	150
3	0.45	150
4	0.70	700

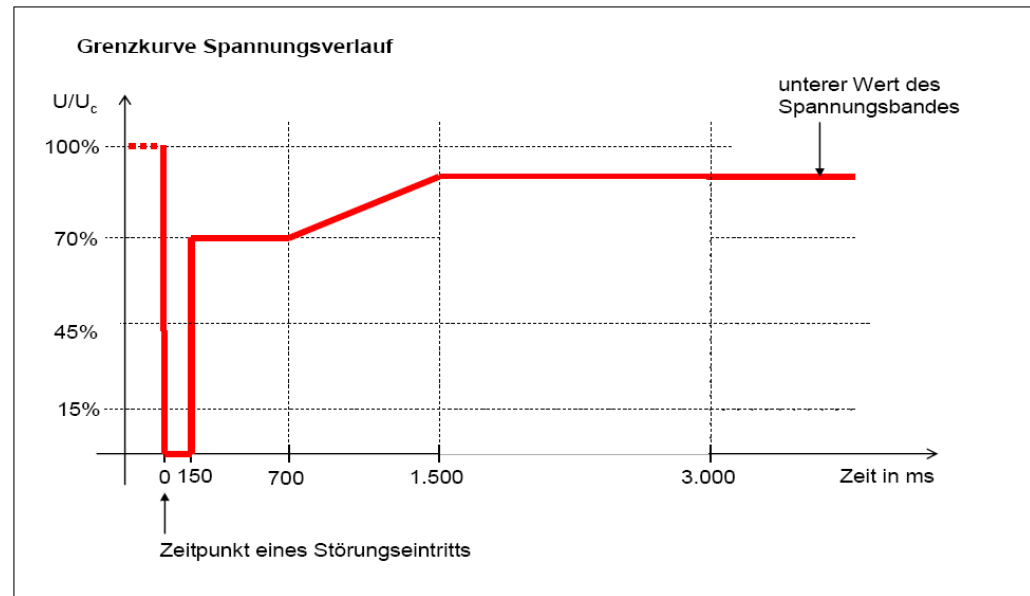

Source: BDEW

² Technische Richtlinien für Erzeugungsanlagen, Teil 3, Bestimmung der Elektrischen Eigenschaften von Erzeugungsanlagen am Mittel-, Hoch- und Höchstspannungsnetz, Revision 19, Stand 14.1.2009, Fördergesellschaft Windenergie e.V.

Simulation results have been analyzed in terms of stability of the CHP plant during and after the fault.

Two stability criteria have been defined for this study:

1. The rotation speed should not exceed 1.1p.u., as protection would disconnect the plant.
2. The rotor angle (with reference to reference machine angle) should not exceed 150° electric, as the generator could fall out of step.

Simulation Base Model: Voltage Dip and Duration

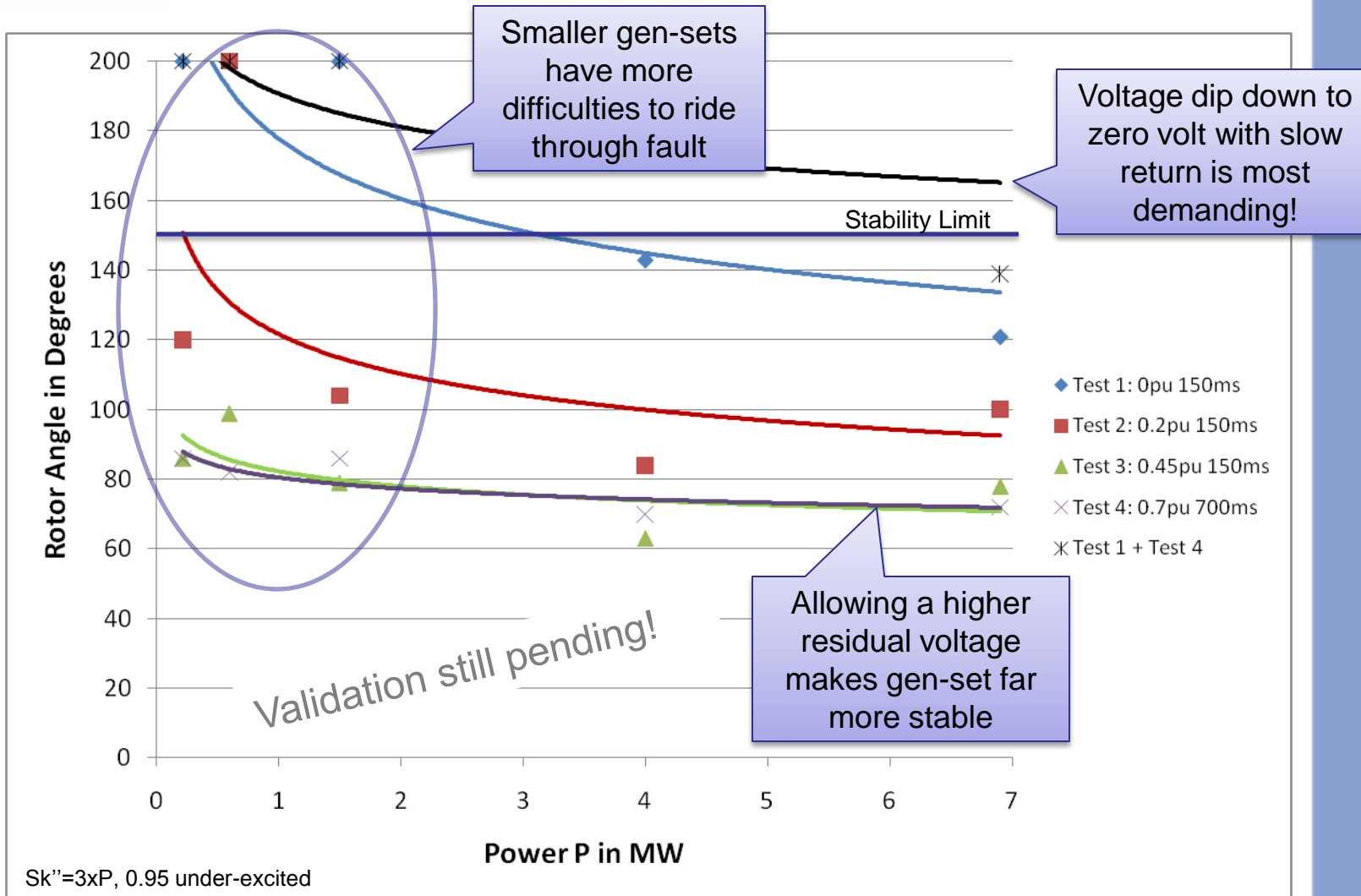

Simulation Base Model: Excitation

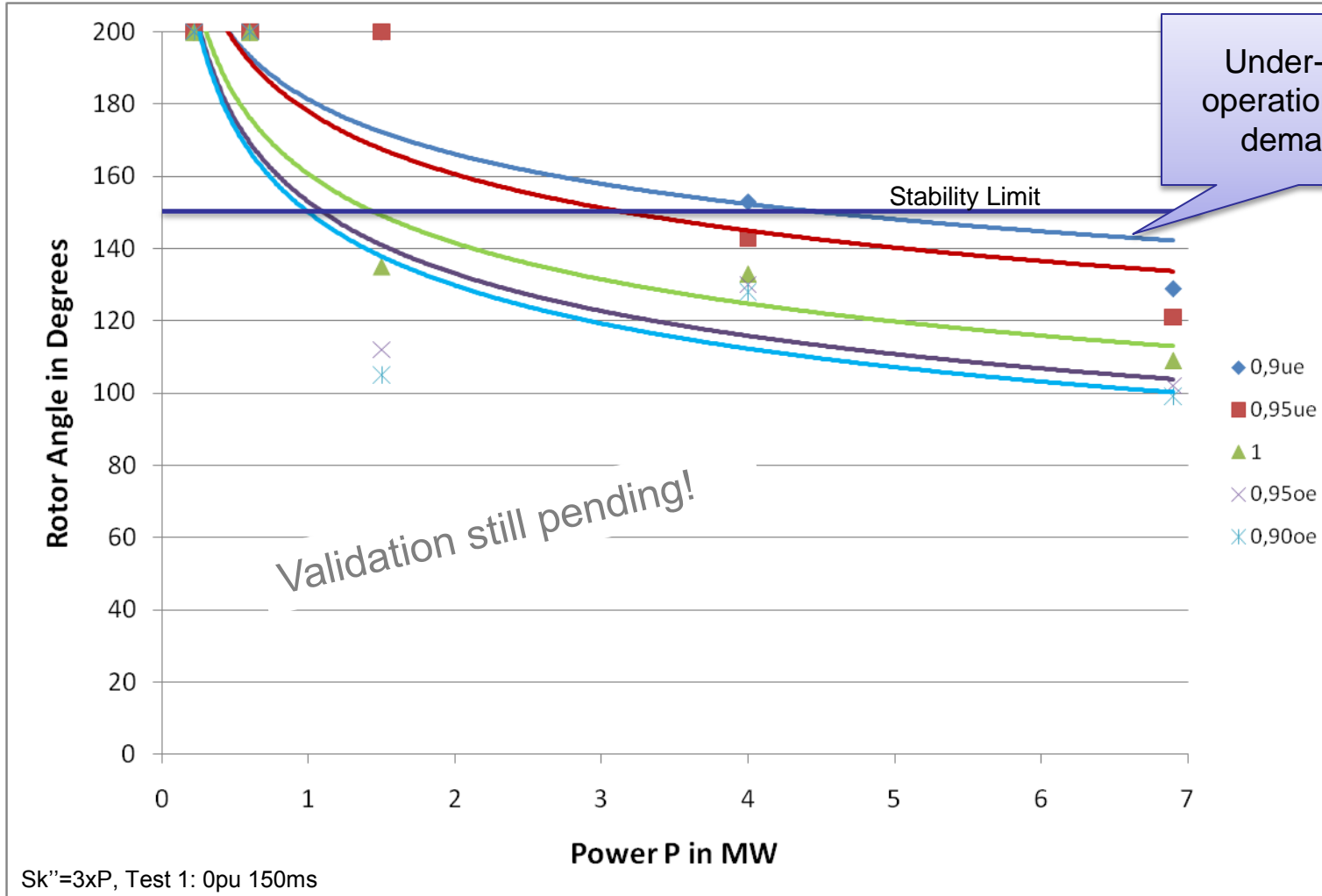

Simulation Base Model: Short-Circuit Power

Three different short-circuit power of the grid have been investigated ($S_{k''}$):

1. $S_{k''} = 3xP$
 - very weak grid
 - minimum power defined by FGW for certification measurements
2. $S_{k''} = 10xP$
 - typical value defined in many grid codes to be used for simulation purposes
3. $S_{k''} = 100xP$
 - strong grid, which is included in the investigation for comparison.

Simulation Base Model: Short-Circuit Power

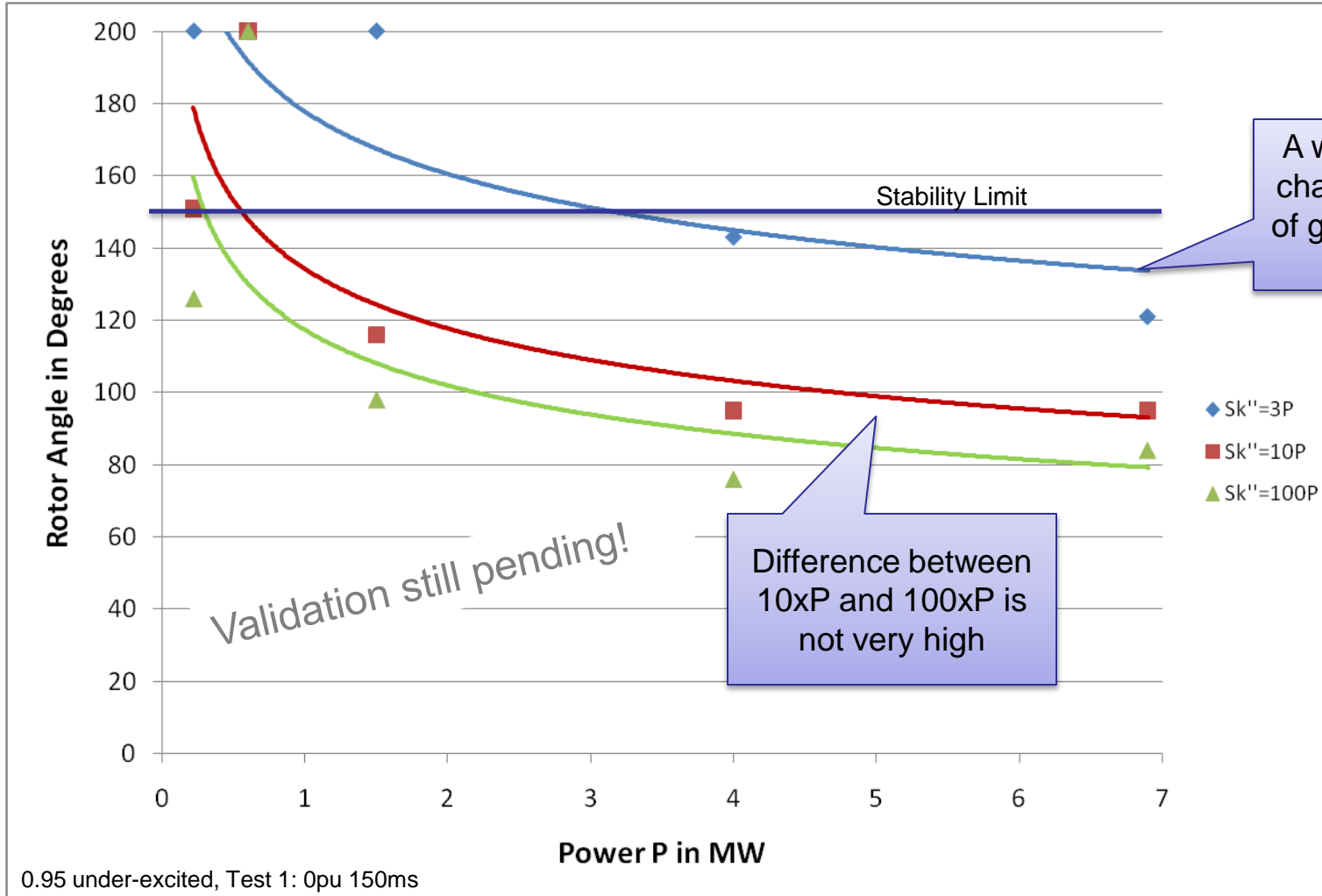

A weak grid is very challenging for FRT of gas engine power plants

Difference between 10xP and 100xP is not very high

Validation still pending!

Simulation Base Model: Conclusions

- Smaller gen-sets have more difficulties to ride through fault
- Voltage dip down to zero volts with slow return is most demanding
- Allowing a higher residual voltage makes gen-set far more stable
- Under-excited operation is most demanding
- A weak grid is very challenging for FRT of gas engine power plants. For certification short-circuit power should be higher than 10 times the rated power.
- High dynamic forces during short circuit and voltage recovery
- **Model has to be validated against real product tests**

Five different FRT solutions have been investigated:

1. Inertia
 2. Parallel Braking Resistor (PBR)
 3. Series Braking Resistor (SBR)
 4. Full Power Convert (FPC)
 5. Eddy-Current Brake (ECB)
- Design and reliability impacts are there but have not been considered in the study

Simulation Results: Inertia

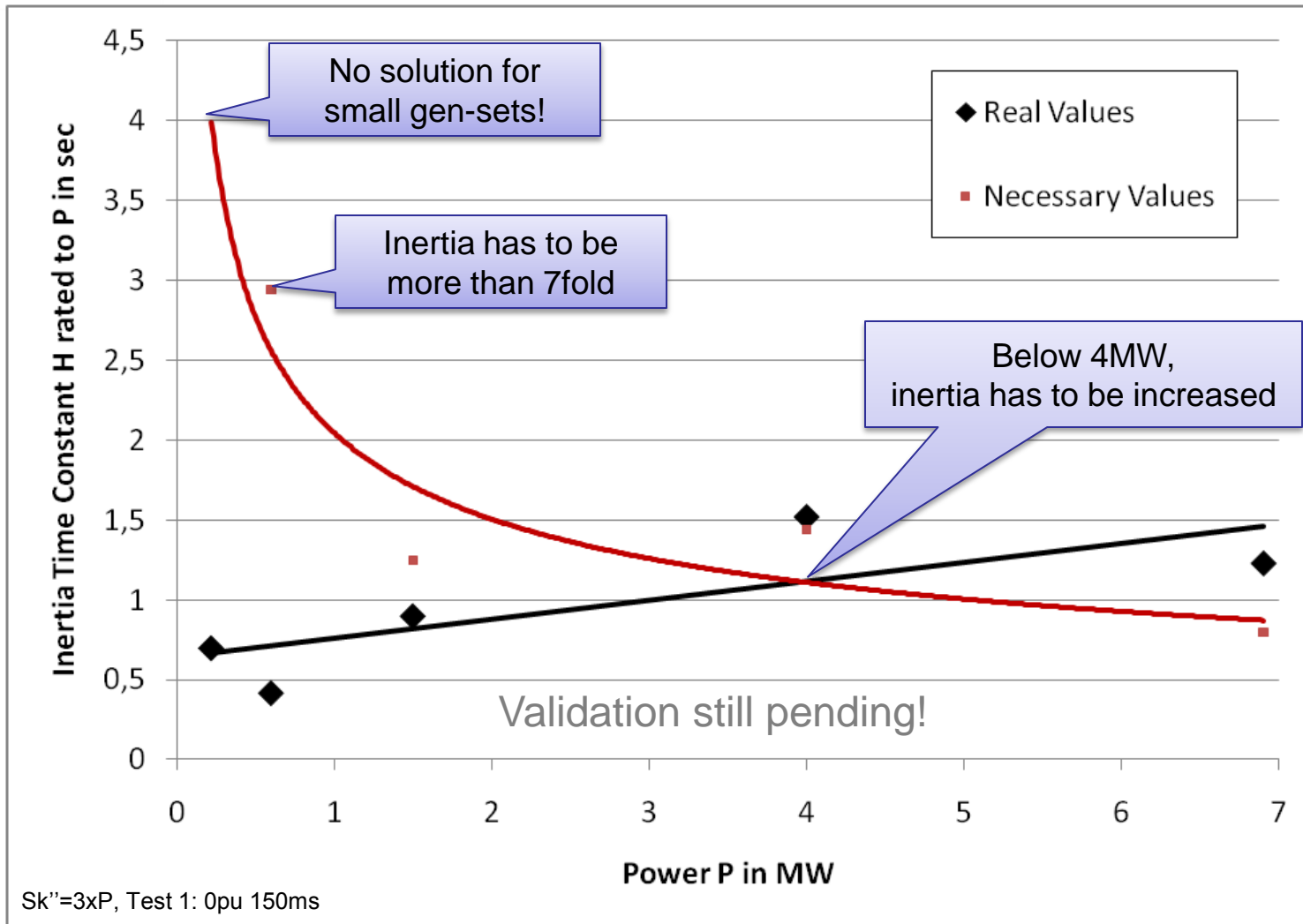

Conclusion: Inertia

- Might be a solution in some cases; for small gen-sets no solution was found or a very high increase is necessary
- High impact on design (e.g. baseframe)
- The cost depends on the required inertia increase – where feasible – necessary to fulfill the event.
- Reduced efficiency due to additional friction losses

Parallel Braking Resistor (PBR) with Inductor (FRT-Box)

- The inductor decouples the generator from the grid. Surplus power is dissipated by the braking resistor.
- Slimmed-down version of the proposed solution from Piller Power Systems (Gridsafe):

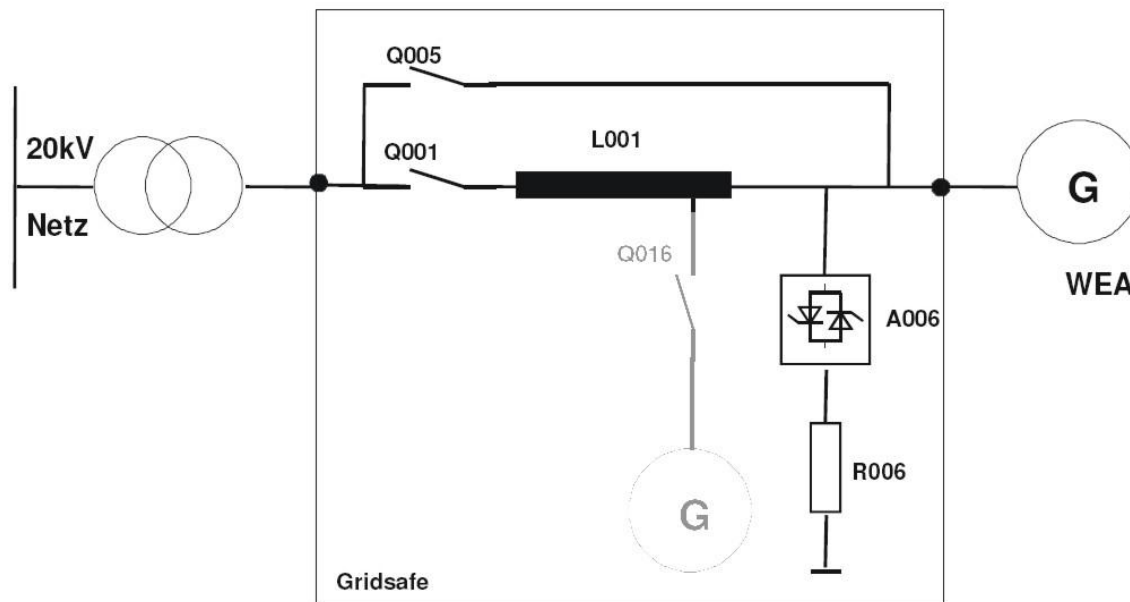

Source: PILLER Power Systems

Simulation Results: Parallel Braking Resistor

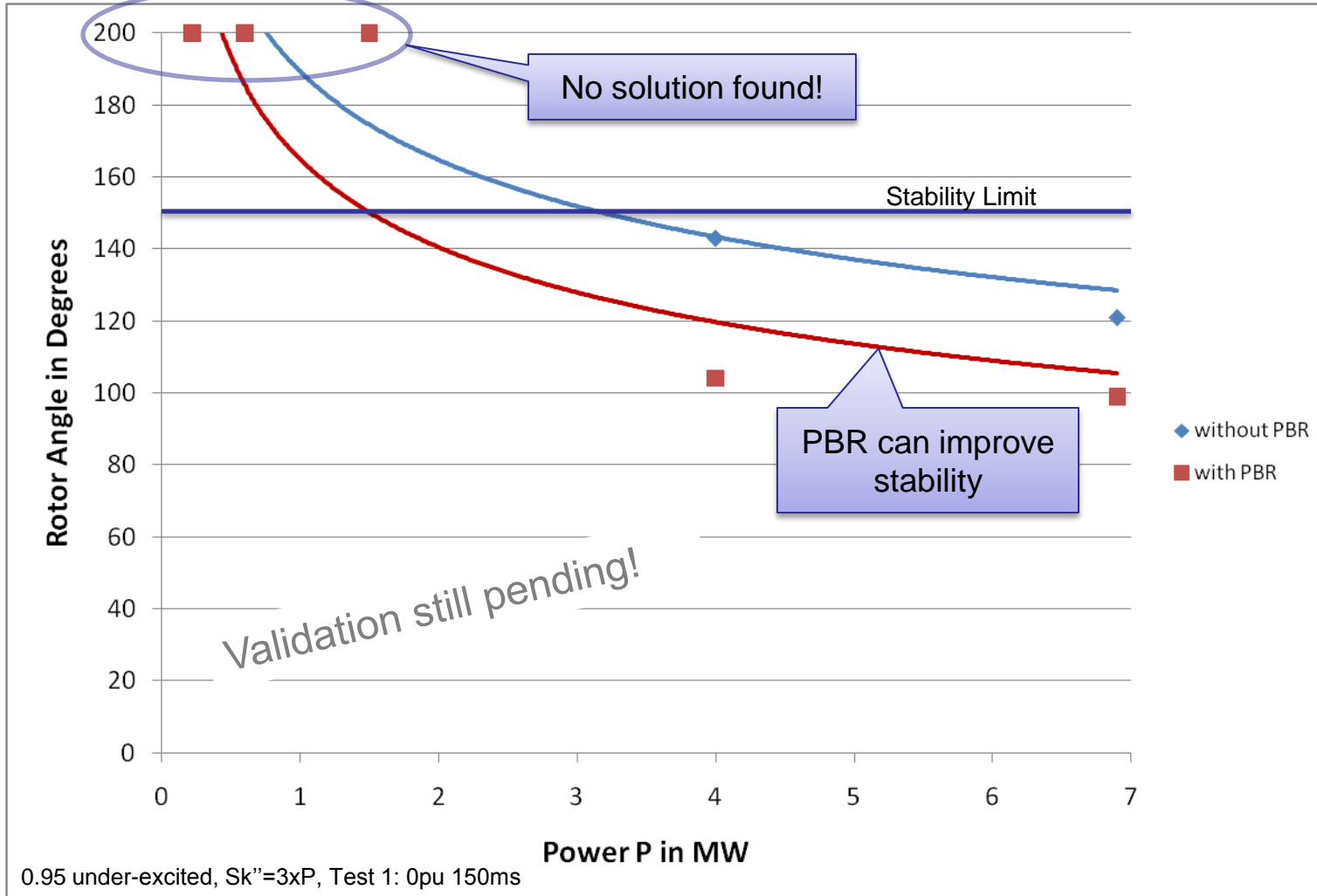

Conclusions: Parallel Braking Resistor

- PBR can increase stability
- For small generators and weak grids no solution could be found.
- Destabilization has been observed in case PBR is inserted during long voltage dips.
- PBR are available on the market, but not ready to use
- PBR costs are high.
- No influence on the efficiency of the gen-set.

Series Braking Resistor (SBR)

- Resistors are located between the terminals of the generator and the PCC (possible fault location) and normally are bypassed.
- During a fault they are activated to dissipate surplus power.

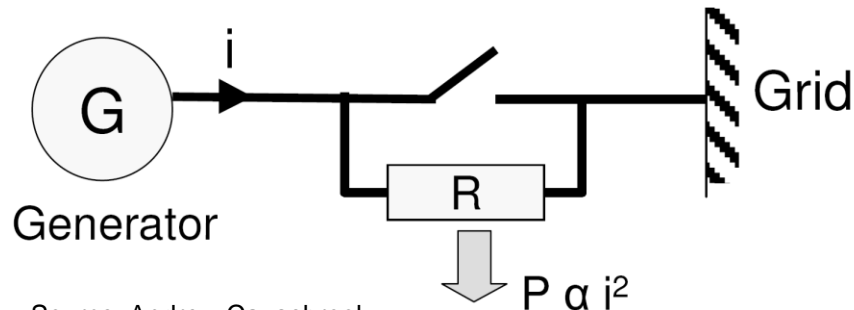

Source: Andrew Causebrook

Simulation Results: Series Braking Resistor

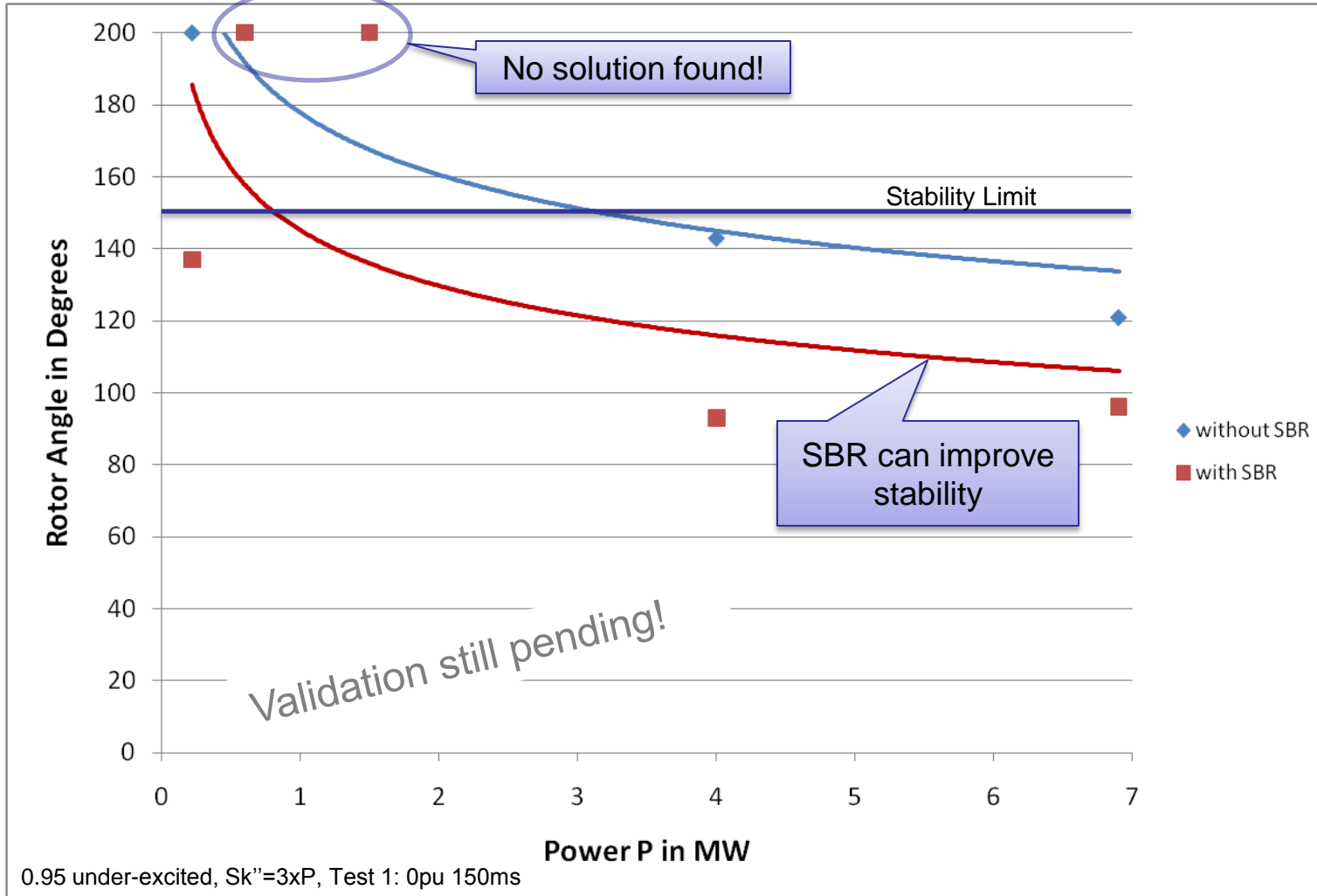

Conclusions: Series Braking Resistor

- Simulation results are very similar to PBR
- Danger of overvoltage at generator terminals when grid voltage returns
- No influence on the efficiency of the gen-set.
- There is no such device available in the market
- Costs are lower than PBR, as there is only one additional breaker and resistor needed.
- SBR seems to be an interesting solution, but has to be further investigated, maybe in follow-up projects

Full Power Convert (FPC)

- By using a full power converter, the grid and generator can be decoupled. This is a proven solution that has enabled wind turbines to fulfill most grid codes.
- Costs are very high
- Efficiency is reduced due to losses in converter
- Reduced short circuit current (≈ 1 p.u.)

Eddy Current Brake (ECB)

- The idea of using an eddy current brake is to keep the speed of the generator during a grid fault within acceptable limits
- Built-up of torque to slow to reduce speed during fault (typically from 200ms up to 4s)
- No eddy current brakes in the required power range available in the market

	Inertia	PBR	SBR	FPC	ECB
Functionality	-	+	+	++	--
Impact on gen-set design	-	o	o	+	-
Costs	high	high	medium	very high	high
Efficiency	-	o	o	-	-
Market availability	+	o	--	+	-
Short-circuit current	+	o	o	-	+

+ positive
o neutral
- negative

Functionality: How well does the FRT solution work?

Impact on gen-set design: Is a redesign necessary, or is it an additional component which can be installed between generator and grid, or are even new improved designs possible?

Costs: How expensive is the FRT solution?

Efficiency: Are there any additional losses to reduce the overall efficiency?

Market availability: Is the FRT solution available on the market?

Short-circuit current: To trip protection of the network, high SC currents are needed. Can these be supplied during the fault by the gen-set?

Positive impacts of gen-sets with Synchronous Generators

- Provide short circuit current (approx. 8pu) for grid protection (FPC would be limited to 1pu)
- Stabilize grid frequency
 - Rotating masses
 - Speed control of generators
- Support grid voltage
- Fast starting compared to big power plants

- Simulations are not validated but can give tendencies
- More difficulties for smaller gen-sets to ride through fault
- Increasing the residual voltage during fault makes gen-set far more stable
- The strength of the grid has a high impact on stability of the gen-set, a weak grid is very challenging
- The functionality of the investigated FRT solutions is very limited. Inertia, PBR and SBR are expected to increase the stability but were not in every case sufficient to make the gen-set FRT capable.
- Usage of the PBR has to be controlled very carefully, as it can destabilize the gen-set.

- The full power converter is expected to cope with every situation but is also the most expensive solution and produces additional losses.
- The eddy current brake is not an alternative
- In every case there are design impacts on the gen-set itself to handle high short-circuit currents and torques and uncontrolled resynchronization when fault is cleared
- None of the solutions has a major negative or positive impact on other parts of the grid codes.
- The potential of the solutions (besides FPC) to comply with other more demanding grid codes is limited.

- Based on these results the Grid operators within VDE-FNN Working group agreed at the last meeting in April to modify the existing German Grid code (BDEW-Mittelspannungsrichtlinie, June 2008)
- The residual power during the LVRT will be modified with a value between 0.2 and 0.4 , exact value is still under discussion.
- Furthermore ramp-up times will be changed to more realistic values for engine driven generators.
- Based on these changes a time schedule for the dynamic requirements was discussed, modified products should be available end of 2012
- Details for Certification are still in discussion within FGW, certificates should be available during 2013 .



energynautics
solutions for a sustainable development



THANK YOU FOR YOUR ATTENTION!

PLUG INTO THE GRID



8-10 June 2010 | RAI, Amsterdam, The Netherlands

POWERGRID
EUROPE 
www.powergrideurope.com